

## DC-DC CONVERTER HFC100-W

RAILWAY CONVERTER.

### FOR CHASSIS AND DIN RAIL MOUNTING



### HIGHLIGHTS

- + Output Power up to 100 Watts\*
- + Efficiency up to 90 %
- + Ultra Wide Input Range
- + Wide Temperature Range
- + Hold-up-time > 10 ms
- + RoHS compliance
- + According to EN50155

### INPUT

<b>Input Voltage Nominal</b>	24, 36, 48, 72, 96 and 110 VDC
<b>Input Voltage Operating</b>	16,8-137,5 VDC
<b>Input Voltage Range</b>	14,4-154 VDC (t ≤ 1,0 sec.) (Class 1C)
<b>No Load Input Current</b>	See table page 2
<b>Internal Fusing</b>	10,0 AT

### OUTPUT

<b>Output Voltage</b>	24 V (other outputs on request)
<b>Initial Set Accuracy</b>	< 2 %
<b>Minimum Load</b>	No minimum load
<b>Short circuit</b>	Continuous short circuit proof
<b>Line Regulation</b>	< 0,5 %
<b>Load Regulation</b>	< 1 % (0 % - 100 % load)***
<b>Ripple &amp; Noise</b>	< 1 % pk-pk, 20 MHz bandwidth
<b>Start Time</b>	< 1,0 s
<b>Max. Output Capacitance</b>	500 uF/A
<b>Temperature Coefficient</b>	< 0.01 %/°C

### FEATURES

<b>Active Reverse Polarity Protection</b>	Max.160 V
<b>Active Inrush Current Limitation</b>	Max.13,8 A (at t > 100 us) < 0,1 A <sup>2</sup> s
<b>Hold-up-time</b>	> 10 ms at full load (Class S2 - V <sub>out nom</sub> ± 4%)
<b>Output Power Good-LED(green)</b>	To indicate Output Voltage
<b>Input Power Good-LED(green)</b>	To indicate Input Voltage
<b>Enable Signal</b>	See page 4
<b>Parallel Operation</b>	Up to 3 converters can be connected in parallel operation. (operating ambient temperature -40°C+55°C)

### PROTECTION

<b>Over Voltage Protection (OVP)</b>	115-125 % V <sub>out nom</sub> . The output switches-off and restarts after 500 ms time.
<b>Over Current Protection (OCP)</b>	I <sub>out nom</sub> > 105 %. The output switches-off when V <sub>out nom</sub> < 90 % and restarts automatically latest after 500 ms of elimination of the overload.
<b>Over Temperature Protection (OTP)</b>	Shutdown at +100-105° C PCB-temp. with about 5° C hysteresis and auto recovery.

### GENERAL

<b>Product Standard</b>	EN 50155:2017
<b>Isolation</b>	2200 VDC Input to Output 1500 VDC Input to Case (PE) 750 VDC Output to Case (PE)
<b>Pollution Degree</b>	PD2 according to EN 50124-1:2017
<b>Switching Frequency</b>	Typ. 125 kHz
<b>Dimensions [mm]</b>	HFC100-W/O-C : 160 x 100 x 40 HFC100-W/T : 160 x 100 x 89
<b>Weight</b>	HFC100-W/O-C : 521 g HFC100-W/T : 640 g
<b>MTBF / Useful Life Class</b>	TBD/ Class L4 (20 years)
<b>Fire &amp; Smoke</b>	EN 45545-2:2016-02 HL3 (R25)

### ENVIRONMENTAL

<b>Operating Ambient Temp.</b>	-40 °C to +85° C* (Class OT4 + ST1, ST2)
<b>Storage Temperature</b>	-40° C to +85° C
<b>Rapid Temperature Variation</b>	Class H1
<b>Altitude</b>	up to 2000 m
<b>Vibration / Shock / Bump</b>	EN 61373:2010, Cat. 1B

### EMC & SAFETY

<b>EMC Standard</b>	EN 50121-3-2:2016
<b>Emissions</b>	EN 55011: 2016+A1:2017, Class B** and meets specifications EMC06_Rangierfunk_02**
<b>Burst</b>	EN 61000-4-4:2012, level 3 (2 kV), Criteria A
<b>Surge</b>	EN 50121-3-2:2016, line to line ±1kV, 42R, and line to case ±2kV, 42R, Criteria A EN 61000-4-5:2014+A1:2017, line to line ± 0,5 kV and line to PE ± 1,0 kV, Criteria A
<b>Conducted Immunity</b>	EN 61000-4-6:2014, level 3 (10V), Criteria A
<b>Radiated Immunity</b>	EN 61000-4-3:2006+A1:2008+A2:2010, 20 V/m, Criteria A
<b>Safety</b>	Designed to meet IEC 62368-1:2014 (second edition)

\* +70 °C continuously, +85 °C max. 10 minutes.

Derating without additional heat sink for Vin Vin 14,4V...20V Ta> 55°C: 1,0 % / °C

\*\* In built-in condition the devices may show different EMC properties.

\*\*\* Value could be higher, depending on the voltage drop of the connector.

# TECHNICAL DATA

For  $T_{amb} = 25^{\circ}C$ ,  $V_{in nom}$ ,  $I_{out nom}$ , unless otherwise specified

## SPECIFICATION Input 14,4 - 154 VDC

TYPE		HFC100-W/O-C / HFC100-W/T						
ORDER NUMBER		87 67 24 0234 3 / 87 67 24 0228 7						
CHARACTERISTIC		Unit						
INPUT	Input Voltage Nominal	V	24	36	48	72	96	110
	Input Voltage Range	V	14,4...36	21,6...51	28,8...67,2	43,2...101	57,6...134,4	66...154
	Under Voltage Turn-on		<15,0...16,8					
	Under Voltage Turn-off	V	<12,0...14,4 (14,4 V < Vin < 16,8 V at t > 1 sec.)					
	Input Current @ Full Load	A	4,80	3,14	2,34	1,56	1,17	1,03
	Input Current @ No Load	A	0,06	0,05	0,040	0,030	0,025	0,020
	Internal Fuse	A	10					
OUTPUT			Output					
	Output Voltage Nominal	V	24					
	Output Current Nominal	A	4,2					
	Output Power	W	100					
	Efficiency @ 60W Load (typical)	%	89	89	90	89	89	89
	Efficiency @ 100W Load (typical)	%	88	89	90	90	90	90
	Output Current limit	A	4,5...5,5					
	Short Circuit Current (typical)	A	14...32 (pulse approx. 2 Hz)*					
Transient Response 25 % / 75 % Load Step Recovery Time < 1 ms	mV	±150						

\* Pulsating current time duration 50 ms

# TECHNICAL DATA

For  $T_{amb} = 25^{\circ}\text{C}$ ,  $V_{in\ nom}$ ,  $I_{out\ nom}$ , unless otherwise specified

## MECHANICAL DETAILS

1. Dimensions in mm
2. Unless otherwise specified, general tolerances  $\pm 1$  are for values in brackets (XX)  
Values not in brackets are according to ISO-2768-1m.

Coating Class PC2: Lackwerke Peters ELPEGUARD SL 1307-FLZ/2  
Protection Degree: HFC100-W/O-C:IP00  
Protection Degree: HFC100-W/T:IP20

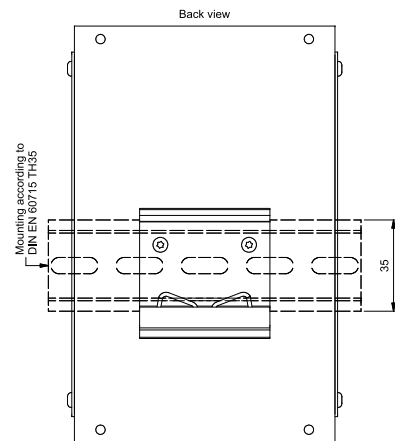
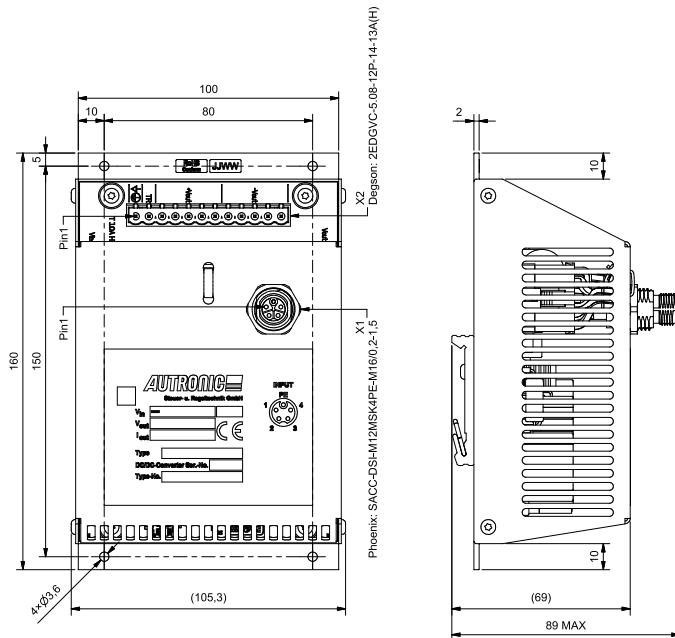
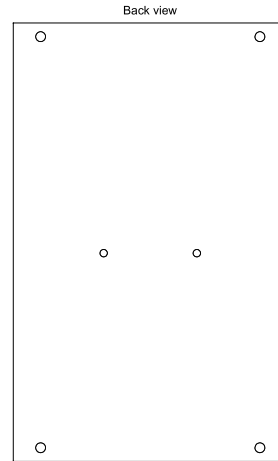
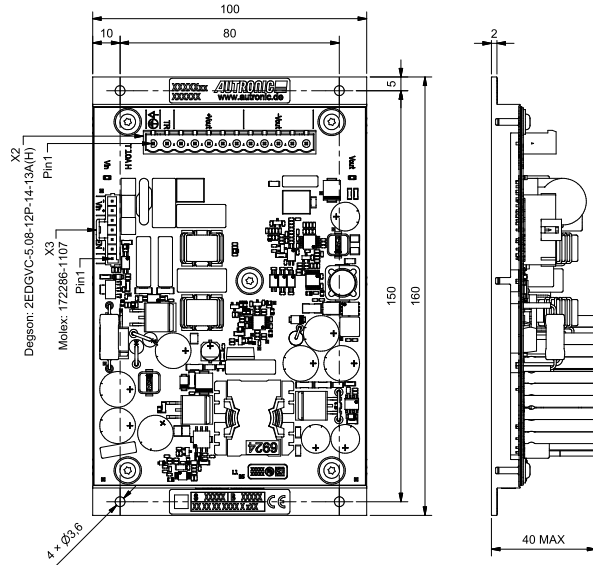

Production acc. to IPC-A-610 (exception bonding)

# TECHNICAL DATA

For  $T_{amb} = 25^{\circ}\text{C}$ ,  $V_{in\ nom}$ ,  $I_{out\ nom}$ , unless otherwise specified

## PINNING

Pin	Function	
X1-1	-Vin	Negative Input Voltage (HFC100-W/T)
X1-2	+Vin	Positive Input Voltage (HFC100-W/T)
X1-3	GND (EN)	GND for Enable (HFC100-W/T)
X1-4	EN	Enable Signal (HFC100-W/T)
X1-5	PE	Potential of the earth (HFC100-W/T)
X2-1	PE	Potential of the earth
X2-2	TR	Tracking
X2-3...7	+Vout	Positive Output Voltage
X2-8...12	-Vout	Negative Output Voltage
X3-1	i.c.	Internal Connected (HFC100W/O-C)
X3-2	GND EN	GND for Enable( HFC100W/O-C)
X3-3	EN	Enable Signal (HFC100-W/O-C)
X3-4...5	i.c.	Internal Connected (HFC100W/O-C)
X3-6	+Vin	Positive Input Voltage (HFC100-W/O-C)
X3-7	-Vin	Negative Input Voltage (HFC100-W/O-C)

## NOTES

### Installation instructions:

The converters have to be installed according to the guidelines currently in force, like other open electronic component assemblies. Attention must be paid to sufficient ventilation, carry off heat, fastening and protection against accidental contact. The mounting surface must be flat and able to remove the thermal energy of converter.

The connection to earth/chassis ground has to be done by the pin X2-1 PE (⚡ / ⊕).

Fault protection: The converters are equipped with a soldered-in-time-lag fuse corresponding to IEC 60127-2 for input protection. In case at fault the supplying current source must be capable to blow the fuse.

Caution for HFC100-W/O-C

1. No protection against touching, dangerous voltage
2. After power off, wait 10 s before disconnecting or touching

## BLOCK DIAGRAM

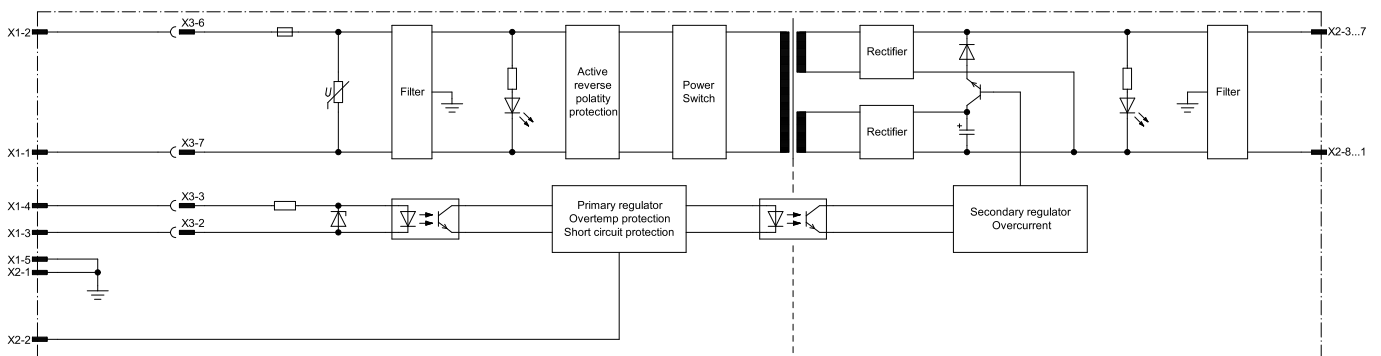

# DESCRIPTION OF FEATURES

## ENABLE SIGNAL

Switched this input EN-Pins to high level  $>3,3\text{ V}$  then the converter switches off.  
This may be done with an external control voltage (V1).

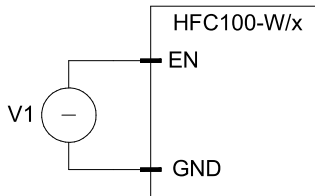

V1:

0...0,8 V (Enable inactive, converter on)

3,3...5,0 V (Enable active, converter off)

Input current: from 2,0mA<sub>min</sub> to 5,0mA<sub>max</sub>

If the signal Enable not potential-free required, then GND can be connected to  $-V_{in}$

When not in use, leave Enable pin not-connected.

## PARALLEL OPERATION

Module of the same output voltage can be connected in parallel operation. If the TR pins of two or more converters are connected, the output voltages in case of short-circuit or overload go synchronously down.

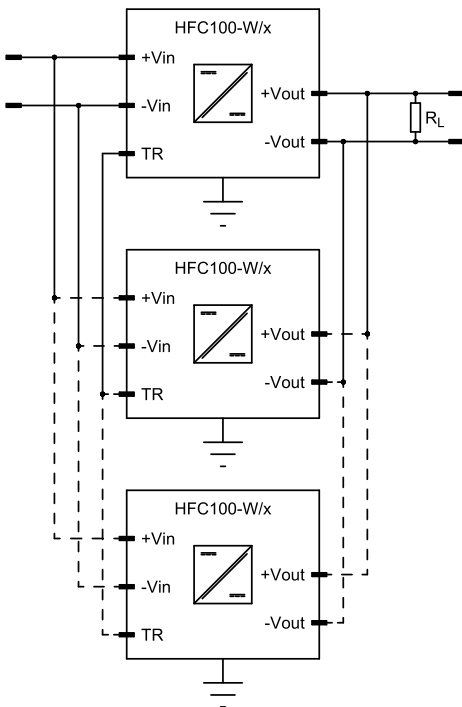

Connection signal TR should be as short as possible (max. 20 cm).  
When not use parallel operation, leave Tracking pin not-connected.

## CHANGE HISTORY

Revision	Date	Author	Modification
a00	2021-05-11	A.Ehrhardt	First edition